

MELUN ANTIQUE GOLD FINISH COMMERCIAL AUTOMATIC SENSOR FAUCET SPECS

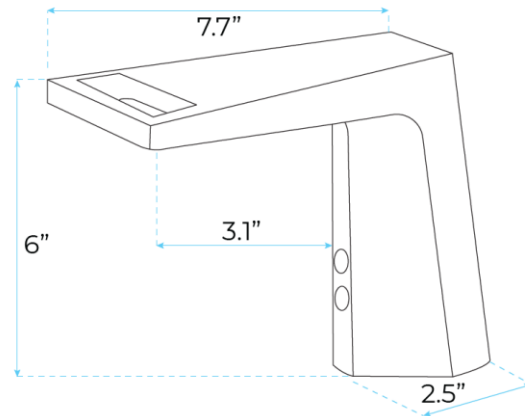

Specs:

- Faucet Mount: Single Hole
- Main body material: 59-1brass
- Power supply: AC/DC (Optional)
- Sensor distance: Factory preset 15cm
- Bubbler: Honeycomb bubbler
- Sensor: Infrared induction
- Battery Box: Waterproof design
- Salt Spray Test: 200 hours of salt spray neutral test
- Configuration: Single cold/hot and cold
- Operating voltage: 220V (According to the customer market)

